

VRN LIQUID RING VACUUM PUMPS



Industrial applications :

- Automatic priming installation for pumping stations
- Filtration under vacuum (Chemical & petrochemical industry, mining industry,..)
- Vacuum condensers (power plants,...)
- Crystallization (sugar mills, ...)
- Concentration, evaporation

Benefits :

- The handled fluids remain free from any grease or oil traces
- Sealing system : available with packing gland or mechanical seal
- Dust- and liquid-proof
- It is possible to pump great amounts of condensable vapours
- This construction produces less noise than any other solution
- Heavy duty design and low maintenance.

ISO 9001 CERTIFIED GROUP

 **Ensival Moret**
A Moret Industries Company

PRINCIPLE OF OPERATION :

/ The vacuum pumps type VRN are composed of a cylindrical casing and of a rotor with blades of which the centerline is in eccentric position in relation to the cylindrical casing. The rotor drives along in its rotating motion a liquid ring which is pushed against the wall of the pump casing by centrifugal force.

/ The impeller being eccentric in relation to the pump casing, its blades dip more or less deeply into the liquid ring depending on their position in the rotating motion. Swept along with the impeller, the liquid acts as a piston by creating variations of the free space between two blades.

/ The figure opposite shows that it is sufficient to position the ports in A and B to obtain a gas pump.

/ The operating characteristics of liquid ring vacuum pumps are thus very similar to those of positive displacement pumps. The shape of the liquid is in theory supposed to be circular. In practice, it appears that such is not the case, but this does not influence the working principle described hereinabove.

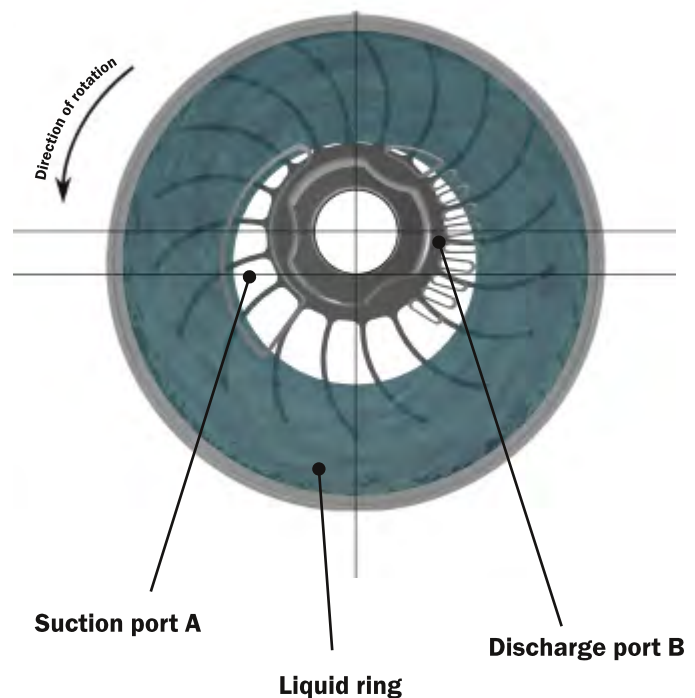

/ Liquid ring vacuum pumps require a constant make-up liquid supply for the three following reasons:

- 1 - the heat generated during operation of the pump must be evacuated
- 2 - a hydraulic sealing must be provided on the packing to prevent air entry
- 3 - the losses of liquid carried away by the sucked-up gas must be compensated in order to maintain an optimum thickness of the liquid ring.

/ The injected liquid ends up with gas at the discharge of the pump. Part of this liquid can be recirculated to the pump if a recovering tank forming separator is used. This makes it possible to minimize the amount of injected liquid. It is nevertheless mandatory to ensure the cooling of the pump; this is why we provide for installations with recovering tank a make-up supply of about 1,5 litre/minute per kW absorbed.

/ The setting accuracy of recirculation and injection flow rates is of prime importance for the smooth operation of vacuum pumps. A too high water flow rate will indeed have the effect of increasing the power absorbed by the pump. If, on the other hand, the cooling liquid flow is not sufficient, the vacuum ring will drop as a result. Besides, any abnormal heating of the liquid ring will cause the sucked-up volume of gas to drop.

As a common practice, it is advisable to adjust the liquid supply flow rate in such a way that temperature rise does not exceed 7 °C when the liquid passes through the pump.

/ In Most applications, the liquid used is water. The diagram on page 5 shows the drop of the inlet flow of gas in function of the temperature of the water forming the liquid ring.

Liquid ring feeding principle :

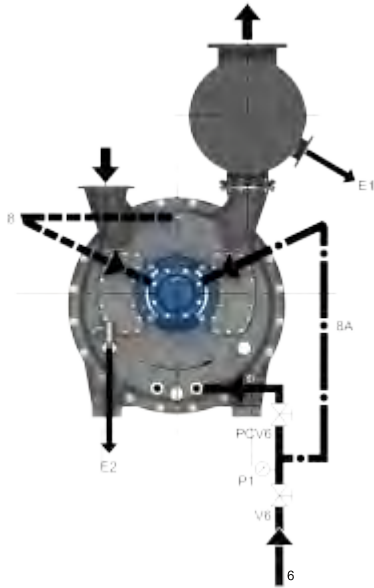

/ Pump without recirculation circuit

- 6 Cooling liquid supply to liquid ring.
- 8 Injection to packing, internal circulation.
- 8A Injection to packing by cold water supply.
- E1 Separator overflow.
- E2 Level overflow in the pump.
- V6 Valve on supply circuit
- PCV.6 Setting of water flow rate to liquid ring.
- P1 Pressure-gauge on cooling liquid supply circuit to liquid ring

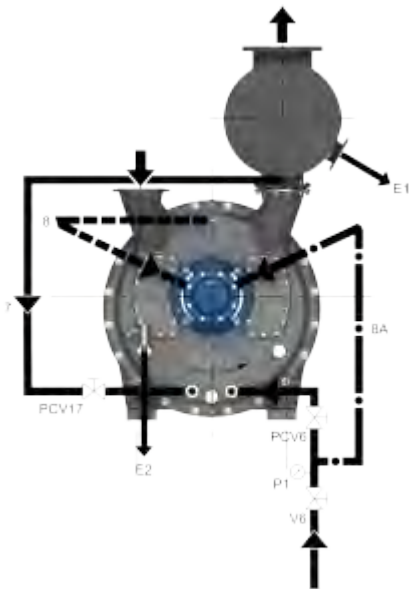

/ Pump with partial recirculation circuit

- 6 Cooling liquid supply to liquid ring.
- 8 Injection to packing, internal circulation.
- 8A Injection to packing by cold water supply.
- 7 Recirculation
- E1 Separator overflow.
- E2 Level overflow in the pump.
- V6 Valve on supply circuit
- PCV.6 Setting of water flow rate to liquid ring.
- PCV.17 Setting valve of water flow rate on liquid ring recirculation circuit
- P1 Pressure-gauge on cooling liquid supply circuit to liquid ring

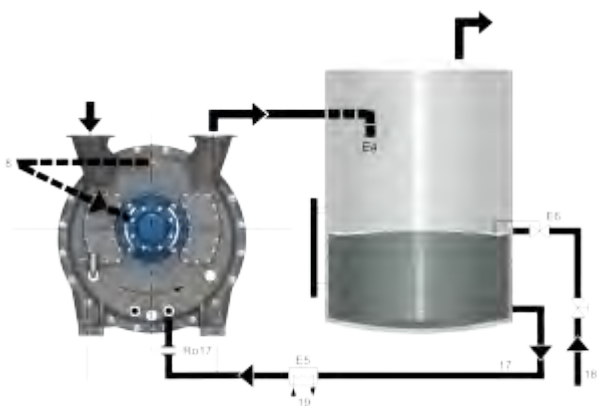

/ Pump with integral recirculation circuit

- 8 Injection to packing, internal circulation.
- 17 Recirculation.
- 18 Cooling water make-up line.
- 19 Cooling water circuit for heat exchanger
- E4 Separator
- E5 Heat exchanger
- E6 Level regulator
- Ro17 Recirculation circuit setting office

SECTIONAL DRAWING :

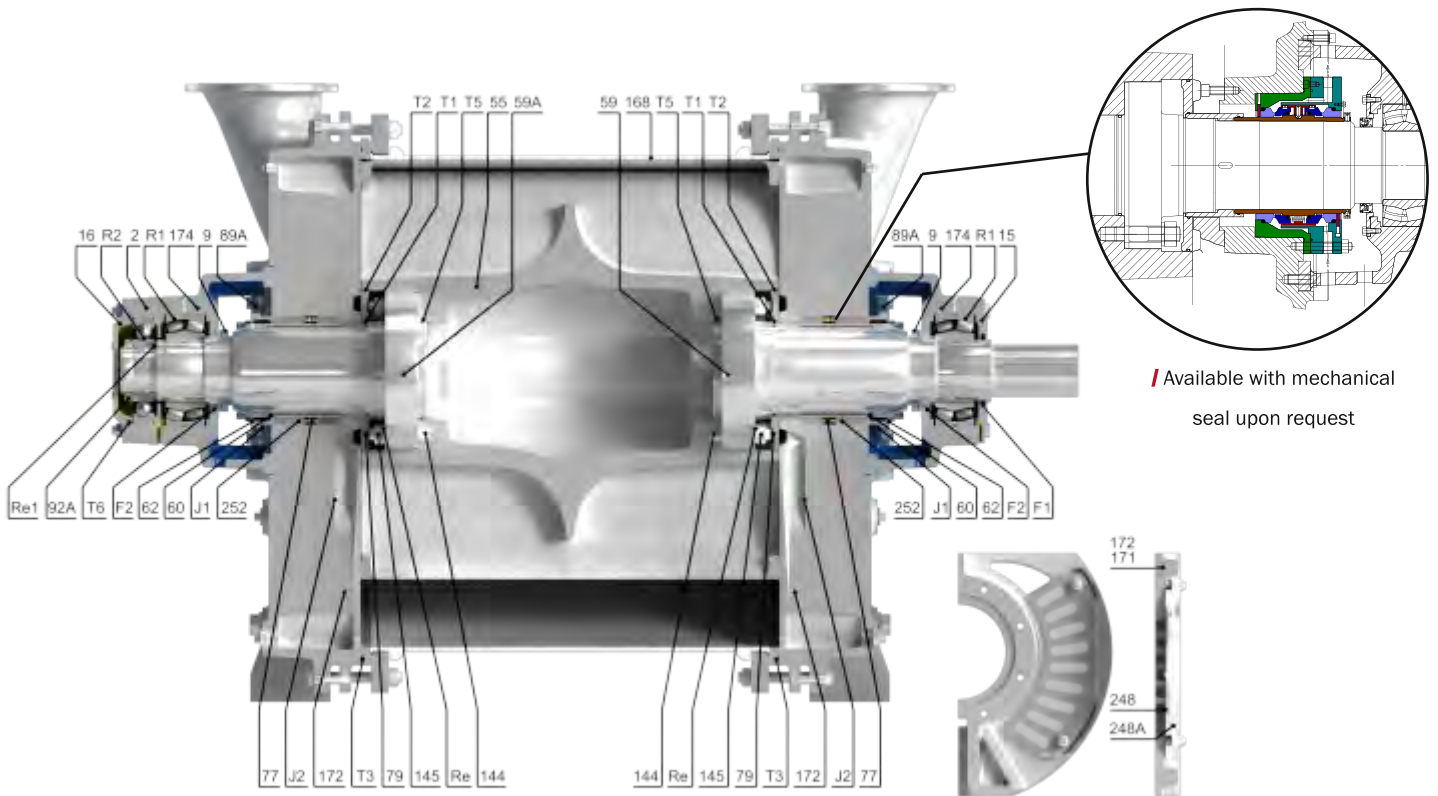

/ List of parts :

2	Bearing housing	92A	Bearing lock out	R2	Axial bearing
9	Deflector disk	144	Stud-bolt	Re	Washer under 145
15	Bearing cover inboard side	145	Nut on item 144	Rel	Setting ring
15B	Inner cover	168	Cylinder casing	F1	Felt-ring in item 15
16	Blind cover	171	Guide plate inboard side	F2	Felt-ring in item 15B
55	Impeller	172	Guide plate outboard side	T1	O-ring between 60 and 79
59	Shaft inboard side	174	Header	T2	O-ring between 55 and 79
59A	Shaft outboard side	248	Flexible membrane on discharge port	T3	O-ring between 171 - 168 and 172
60	Shaft sleeve	248A	Membrane cover	T4	O-ring between 15B and 174
62	Two piece gland	252	Packing ring	T5	O-ring between 59-55-59A
77	Lantern ring	R1	Radial bearing	T6	O-ring in item 2
79	Protecting ring	J1	Gasket between 89A & 174	J1	Gasket between 89A & 174
89A	Inspection port on item	J2	Gasket between 171 - 174 and 172	J2	Gasket between 171 - 174 and 172

/ Materials of construction

/ Cast iron - Steel

FT25 : cylinder / guide plates / headers
GGG40 : impeller
CK35 steel : shaft

/ Stainless steel / Duplex materials

Stainless steel : cylinder / guide plates / impeller
CK35 : shaft (entirely protected)

/ Separator tank and suction manifold in fiberglass is optional

/ Other materials are available upon request

DIMENSIONAL DRAWING :

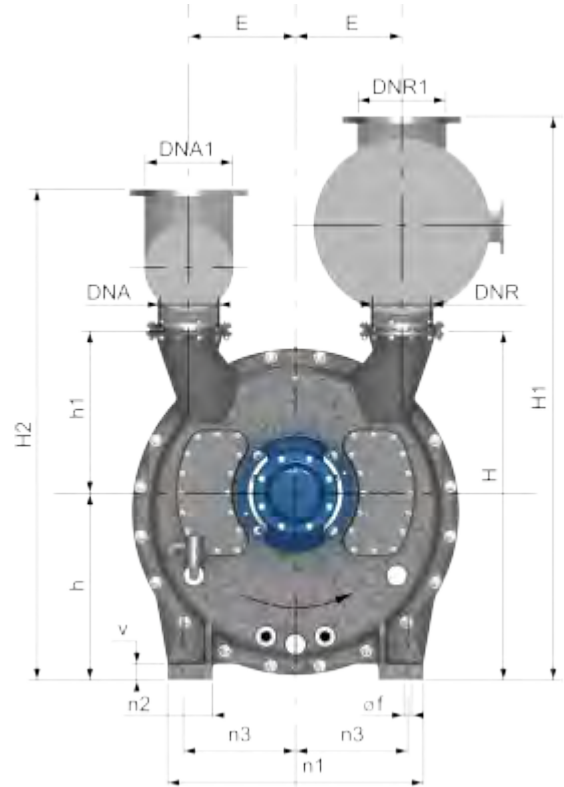
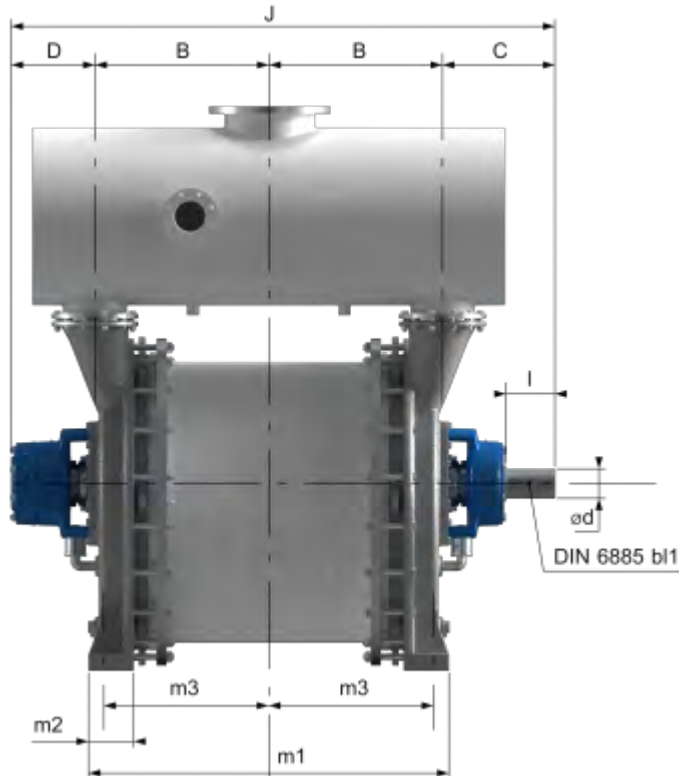

Type	CONNECTIONS				Pumps												
	DNA	DNR	DNA 1	DNR 1	B	C	D	E	J	h	H	H1	H2	m1	m2	m3	
VRN 8A	100	100	125	150	325	315	270	200	1235	375	325	700	1152	952	730	80	335
VRN 8B	100	100	125	150	250	315	270	200	1085	375	325	700	1152	952	580	80	260
VRN 10	125	125	150	200	395	342	277	243	1409	435	395	830	1375	1120	890	100	405
VRN 12	125	125	200	250	445	354	300	270	1544	500	410	910	1540	1250	1025	125	462,5
VRN 14	150	150	200	300	504	406	314	315	1728	560	475	1035	1687	1387	1151	140	520,5
VRN 16	200	200	250	300	580	410	325	360	1895	625	560	1185	1965	1600	1290	150	590
VRN 18	200	200	250	350	670	440	340	410	2120	705	650	1355	2244	1830	1475	175	675
VRN 20	250	250	300	400	764	478	360	472,5	2366	800	750	1550	2565	2090	1678	200	769
VRN 22	300	300	350	450	883,5	573,5	426,5	540	2767	960	825	1775	2867	2497	1833	230	863,5
VRN 24	350	350	400	500	1016	674	509	621	3215	1100	950	2050	-	-	-	-	-

TYPE	PUMP					SHAFT END	
	n1	n2	n3	øf	v	ød	v
VRN 8A	530	100	220	25	40	70	105
VRN 8B	530	100	220	25	40	70	105
VRN 10	620	110	260	25	40	80	130
VRN 12	700	130	290	30	45	85	130
VRN 14	800	150	330	40	50	100	170
VRN 16	875	160	365	40	50	110	165
VRN 18	990	175	415	40	60	120	165
VRN 20	1120	200	470	40	60	130	200
VRN 22	1300	230	570	40	80	150	250
VRN 24	-	-	-	-	-	160	300



/ Transmission with belt drive



/ Transmission with gear box

Coverage charts :

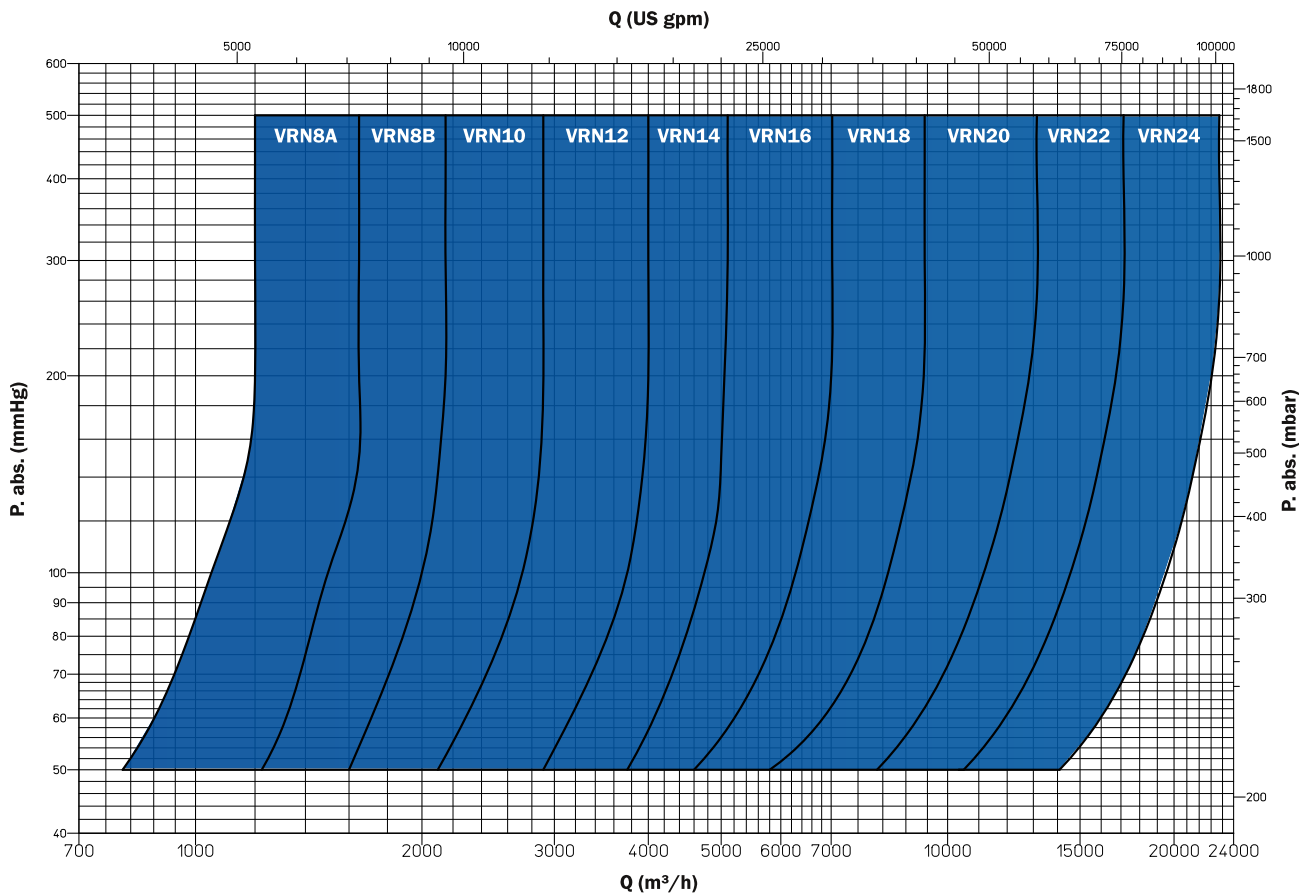

/ Higher capacities upon request

/ The present chart is only applicable for the pumping of dry air at 20 °C, a discharge pressure of 760 mmHg and a cooling water temperature of 15 °C.

/ The influence of the hygrometric degree of the air and of the cooling water temperature is shown on the figures on opposite page.

/ In the case of sealing or injection liquid other than water and of a discharge pressure different from atmospheric pressure or when high solubility gases (CO₂) are pumped please consult our technical service.

Influence of water ring temperature and of the hygrometric degree of the inlet air capacity :

/ Drop in suction volume in relation to water ring temperature.

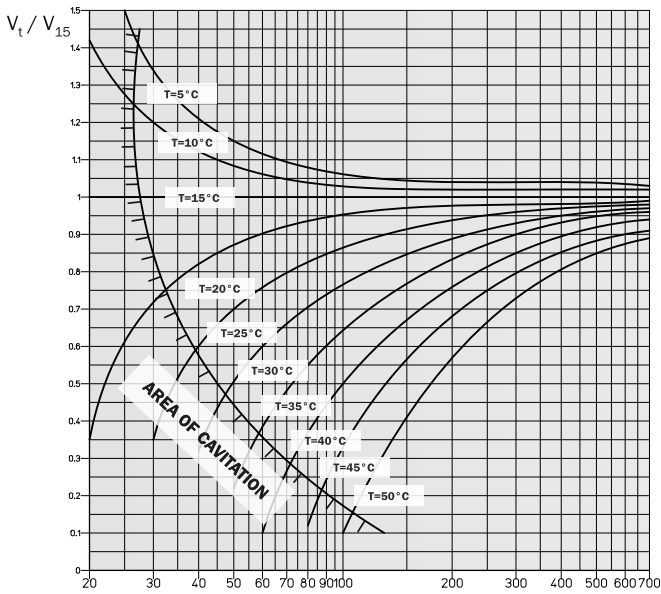

V_{15} = Inlet capacity for a water ring temperature of 15°C
 V_t = Inlet capacity for a water ring temperature of T°C

/ Suction Volume correction for humidity-saturated air.

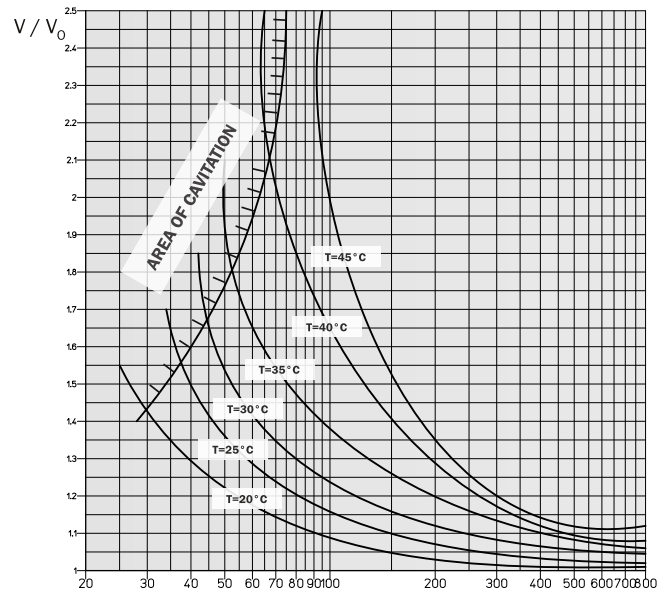

V = Inlet capacity for humidity saturated air at temperature T°C
 V_0 = Inlet capacity for dry air at 20°C
 Water ring temperature = 15°C

Compression ratio regulation :



/ If a liquid ring pump is to operate at its maximum efficiency point, the size of the discharge ports must be adapted to the compression ratio to be achieved.

/ In the VRN vacuum pump, the port plates are provided with flexible membranes facing the discharge ports.

/ The position of these membranes depends on the distribution of pressure prevailing in the liquid ring. In this way, the total discharge port surface is always automatically adjusted according to the compression rate produced.



ENSIVAL MORET FRANCE

Chemin des Ponts et Chaussées
F-02100 Saint-Quentin
Tel : +33 (0)3 23 62 91 00
Fax : +33 (0)3 23 62 02 30
Email : emstquentin@em-pumps.com

ENSIVAL MORET FRANCE

59 Avenue du Danemark
F-37100 Tours
Tél : +33 (0)2 47 88 31 31
Fax : +33 (0)2 47 41 51 73
Email : emtours@em-pumps.com

ENSIVAL MORET FAPMO

35, 37 Rue Roger Salengro BP59
F-62230 Outreau (FRANCE)
Tel : +33 (0)3 21 10 01 21
Fax : +33 (0)3 21 80 46 88
Email : fapmo@em-pumps.com

ENSIVAL MORET AMERICA, Inc.

7901 SouthPark Plaza, Suite 102
Littleton, Colorado - 80120, USA
Office : 303-798-4454
Fax : 303-798-4199
sales@em-america.com

ENSIVAL MORET BELGIUM

Bois-la-Dame, 4 Z.I. les Plenesses
B-4890 Thimister-Clermont
Tel : +32 (0)87 46 81 11
Fax : +32 (0)87 46 81 00
Email : info@em-pumps.com

ENSIVAL MORET DEPLECHIN

Avenue de Maire, 28
B-7500 Tournai (BELGIUM)
Tel : +32 (0)69 89 00 89
Fax : +32 (0)69 89 00 60
Email : emtournai@em-pumps.com

ENSIVAL MORET ASIA

31 Mandai Estate
#07-07 Innovation Place - Tower 4,
Immedia
Singapore 729933
Tel : +65 6281 06 67
Fax : +65 6281 09 08
Email : emsingapore@em-pumps.com

ENSIVAL MORET INDIA Pvt. Ltd.

702A Oxford Hallmark
Lane 7 Koregaon Park
Pune 411 001 - INDIA
Tel: +91 (0)20 4128 5783
Email: emindia@em-pumps.com

ENSIVAL MORET (SHANGHAI) CO., LTD.

No. 1590, Li An Road,
Minhang District,
Shanghai 201199 - P.R. CHINA
Tel: +86 (0)21 5488 9599
Fax: +86 (0) 21 5488 9399
Email: emshanghai@ensival-moret.cn

ENSIVAL MORET DO BRAZIL

Distrito Industrial Bandeirantes
Rua País de Gales, 128
CEP 13.326-195 Salto-SP - BRASIL
Tel/Fax : (55) 11 4602 9595
Email: info@em-brasil.com